



# APCS

# NEWS

The Newsletter of the Australia Photographic Collectors Society

Issue 54

November 2015

Incorporation Registration No. A16888V

ABN 55 567 464 974

PRESIDENT – Rod Reynolds 0408173662

president@apcsociety.com.au

SECRETARY- Margaret Mason 03 9836 3719

secretary@apcsociety.com.au

TREASURER – John Young

treasurer@apcsociety.com.au

NEWSLETTER – (Editor- Andrew Korlaki)

andrew@korlaki.com

Meetings & Auctions are held at the

Australian Model Railway Hall

92 Wills Street

Glen Iris

Melways Ref 59 H7

## President's Column

The greatest asset of the APCS is its members, and your details are in a database which is in part out of date, and in part incomplete. New tools allow automated systems to convert the data into printed envelopes, letters etc., but the results are only as good as the accuracy of the data.

You saw the database at work a week or so ago in a letter that was sent to you at your last known physical address – specifically asking you to update the information that was there. About 15% of you have sent in new data – thank you. Importantly for the future of the APCS, your membership status was also included and that has prompted several to pay their overdue subs – thank you for that too. We sent these letters to all who had been members at least up to June 2013 as it seems that more than 40% of the members at that time had lapsed.

A more complete database will allow newsletters and special notices to be delivered by email, although you will still be able to download the current newsletter from the APCS website. From now on, membership renewals will be advised by personalised emails just before the due date.

For the time being we will keep a register of members that don't have email addresses and they will receive

key advices by direct mail, but at best such advices will be delayed.

The concept of eMembers is gathering strength with more than a dozen people registering at the last Market – we welcome them and trust that they will become full members in time.

Rod Reynolds – President

## Social meeting next Sunday 15<sup>th</sup> Nov at 2pm – AMRA Hall.

The next meeting is a social get-together for all members and friends. This is a free event but please phone Margaret at (03)98363719 or email [secretary@apcsociety.com.au](mailto:secretary@apcsociety.com.au) to facilitate catering.

## Voigtlander rangefinder film cameras discontinued.



Cosina in Japan has announced the discontinuation of all Voigtlander Bessa R2-M, R3-M, R4-M, R2A, R3A and R4A 35mm rangefinder cameras,

along with a large number of lenses and accessories as a result of declining sales. New stock is still available from various retailers worldwide. For more info visit <http://www.cosina.co.jp/seihin/voigt/english/dispo.html>

## \$2 Tintype photo is worth millions

In 2010 Randy Guijarro purchased a Tintype photo in a junkshop for \$2. The photograph has now been authenticated as a photograph showing Billy The Kid and members of his gang – only the second authenticated photograph of the famous outlaw ever discovered. The story was even the subject of a recent documentary that was broadcast on the national Geographic Channel in America. For more information on this fascinating story visit <http://kagins.com>

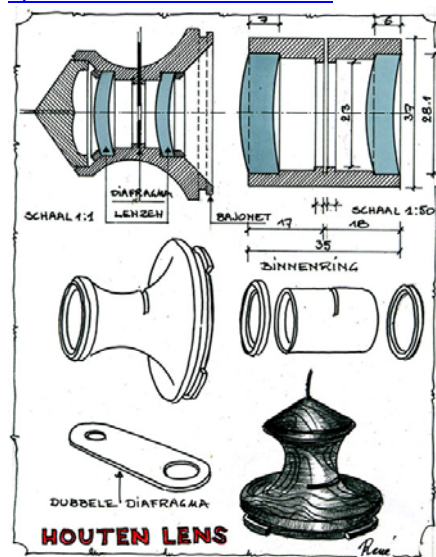

photo kagins.com

## An unusual piece of woodworking

This could well be the first lens made out of wood, although cameras out of wood are common. Rene Smets, a Belgian photographer with a love of woodwork constructed this unique lens out of 2 different types of wood.

Facebook members can visit his page <https://www.facebook.com/rene.smets.9> for examples of photos taken with the lens, and the construction process involved. If you are not a member you can see more at: <http://phogotrphy.com/2015/10/14/rene-smets-wooden-lens>



## Amazing new high speed full frame lenses

Made in China no longer means what it used to.... just take a look at the latest offering from Zhong Yi Optics, trading as Mitakon and Zhongyi – a 135mm f1.4 lens that covers full frame 35mm! The new Speedmaster is constructed of 11 elements in 5 groups, and weighs a whopping 3KG! Only around 100 of these lenses will be produced in Canon EF, Nikon F

and Sony FE mounts. And the price??? \$2999 US. For more details and to order one (US\$500 non-refundable deposit!) visit their website:

<http://www.zyoptics.net/product/pr-e-order-mitakon-speedmaster-135mm-f1-4>

(Note: This is one of the new super-fast lenses and optical devices from Mitakon – reviewed well among several competitors challenging the reputation of the Leitz 50mm f0.95 Noktilux for example!)



## Uncommon cameras for sale at two upcoming Auctions

There are some uncommon cameras for sale at the upcoming Tamarkin Auction in the USA. Highlights include a 1888 Kodak (serial number 885), a V-Pan 6X17cm monorail camera outfit, a NIKO-MAR IV underwater housing for a Nikon FEA (a Nikon FE with a fixed Action finder – which is included), and a Hegelein Watch Camera (also known as a Anthony's Watch Camera) – only the 4<sup>th</sup> example known to exist. To download the catalogue visit <http://www.tamarkinauctions.com>



At the upcoming WestLicht Auction in Vienna there is a large variety of rare photographic items for sale including a Foto Fex Minifex fitted with the high speed f1.8/25mm lens, a Nikon SB-140 flash that was designed for Infra Red and Ultraviolet photography with special Nikon UV lenses (estimate is 1200-1400 Euro)



Also on offer are a Polaroid SX-70 in a Ikelite underwater housing, a Compendica Vaduz Liechtenstein 88/16A (possibly the only camera made in Liechtenstein), a 16mm combined movie and still camera, and a Mephisto Box camera that takes 5 4x6cm glass plates: made of metal, it is one of 3 known to exist.



However the highlight for your Editor is one of the most interesting advertising pieces he has ever seen, an Exakta II store display that was made by the Exakta factory... have a look at how it dwarfs the "real" camera in the photo below:

For further info visit their website - <http://www.westlicht-auction.com/index.php?id=4>

